

Programmable 2.5GHz RF over Fiber



Key Features:

- Next-generation RFOF modules with significant performance improvement.
- Supports 0.001GHz to 2.5GHz for GPS and GNSS.
- Better linearity, excellent gain flatness, and Tx, Rx, and Link gain control.
- Noise Figure down to 6 dB with LNA with MDS ~-168 dBm/Hz for very low incoming signals.
- Excellent Phase Noise
- Internal microcontroller allows RF and Optical control, enabled by software.
- End-to-end diagnostics reduces installation and maintenance time, enabled by software.
- Gain variation S21 (fo) of ± 1 dB for 100°C variation, utilizing special algorithm.
- Remote management by GUI installed on PC.
- Impedances of 50 and 75 Ohm

Monitoring:

- Managed remotely by software or locally through a navigation switch

Configurations:

- Outdoor enclosure (unidirectional/bi-directional)
- 1U Generic enclosure (4 units)
- (1,2,3)U Removable panel enclosure (4/8/12) units

Applications:

- Remote Antennas Communication
- Satcom
- 4G LTE
- Broadcast
- Distributed Antenna
- Radio telescopes

RFOptic's innovative controllable RFOF product line consists of palm-size analog RFOF modules that are used to convert RF signals to optical signals to carry over long distances. The Tx unit using an optical transmitter converts RF to the optical signal, and the Rx unit converts back to then RF signal. The two units are connected through the customer's single-mode fiber.

RFOptic's RF over Fiber (RFOF) modules are suitable for telecommunications, satellite, radio telescopes, distribution antennas, broadcasting audio and video, and timing synchronization. For example, point-to-point antennas can be connected from several meters to many kilometers away from the control room by fiber cables; Base stations can be connected through fiber to remote sector antennas; Satellite antennas can be connected through fiber cable to remote sites by RF over Fiber solutions.

Both the Tx and Rx units include LNAs and variable attenuators that enable the customer to adjust the Noise Figure, Input P1dB, and IP3 with wide dynamic range values. The LNA can be operated through the RFOF software allowing RF input power in the range of -100 dBm/1MHz for wideband applications, with a low Noise Figure of 6 dB. The RFOF link has excellent gain flatness with 0.5dB gain tracking between different links. For special applications requiring temperature stability operation, a unique algorithm supporting ± 1 dB over 100°C has been developed. The DC power of the RFOF modules is flexible from 5 to 12 Volts.

A user-friendly RFOF software enables adjustment of the RF and Optical parameters, such as link gain, Noise Figure, P1dB, Optical power, LED indication and module information, either locally or remotely.

Furthermore, the RFOF link has full diagnostic capability, including Tx, Rx, and complete link test (Optical and RF). These features save the cost of test equipment and provide real-time diagnostics of any deployed link.

The [link gain calculator](#) helps to calculate the link gain and the optical predicted parameters for RFOptic's programmable RFOF family.

Programmable 2.5GHz RF over Fiber specifications

Electrical	Unit	Specification (typical)	Specification (typical)
		LNA "OFF"	LNA "ON"
Frequency Range	MHz	1 - 2500	1 - 2500
Adjustable Link Gain (nominal value) ^[1]	dB	12	42
Attenuator range 31.5dB (Tx, Rx) step ^[2]	dB	0.5	0.5
Gain Flatness	dB	±1.4	±1.4
Input P1 dB ^[3]	dBm	-3	-33
Noise Figure ^[3]	dB	25	5
SFDR ^[3]	dB/Hz ^{2/3}	104	100
Gain Flatness any 36GHz	dB	±0.25	±0.25
Uncorrected gain variation over temperature	dB	±3.5	±3.5
Corrected gain variation over temperature ^[4]	dB	±1.5	±1.5
Corrected gain tracking between RFoF links ^[5]	dB	±0.5	±0.5
Maximum Input No damage	dBm	20	20
Spurious (input signal at 1p1dBc - 3dB at 1GHz) ^[6]	dBc	-85	-75
Phase Noise at 2GHz at 10KHz Offset	dBc/Hz	-150	-
VSWR Input / Output	dBm	1.7:1	1.7:1
Input / Output impedance ^[7]	Ohm	50	50
Optical and Electrical			
Current consumption of Tx unit (at 5VDC)	mA	260	385
Current consumption of Rx unit (at 5VDC)	mA	225	
Laser diode wavelength	µm	1.31 or 1.55	
Optical Power in the fiber	mw	2.3 ±0.5	
LED status indicators (Tx/Rx)	-	RGB	
Mechanical and Environmental Parameters			
Operating temperature ^[8]	°C	-20 to +70	
Storage temperature	°C	-40 to +85	
EMC and Safety ^[9]	-	CE & FCC	

RFoF 2.5GHz module options:

Parameter	RFoF Tx/Rx Units	19" 1U Enclosure for RFoF	RFoF 2.5GHz Outdoor
Dimensions (mm)	70(W)*70(L)*22(H)	19" 1U Generic: 445(W)*476(L)*44(H)19" 19" 1/2U Removable: 442(W)*402(L)*44(H)	Big Outdoor: 330(W)*350(L)*85(H) Small Outdoor: 270(W)*230(L)*85(H)
Number of units	—	Up to 4 / Up to 8	Up to 4 / Up to 6
RF I/O Connector	SMA female	SMA female	N Type female
Optical Connector	FC/APC or SC/APC	FC/APC or SC/APC	MPO/APC 4/8 male ^[10]
Data Connector	Micro USB	USB2/RJ45 ^[14]	RJ45 female ^[11]
Power Connector	PIN 3.5*1.3*9 mm	HP Socket ^[13]	DC female/ AC male ^[11,12]
Power	5—12 VDC	110 / 220 VAC	9—36 VDC / 110 / 220VAC

- [1] LNA 'ON' or 'OFF' is factory set by RFOptic or by using RFoF user software.
- [2] 'No Attenuation' is the default setting for Tx & Rx units. Attenuation values of 0 - 31dB in 0.5dB steps can be selected via the user software.
- [3] Noise Figure, Input P1 dB, Input IP3, and SFDR (measured at 1.5GHz), can be selected by 'LNA Off/ON' and the Tx Attenuator.
- [4] Using the software's internal temperature compensation algorithm.
- [5] Using the Tx and/or Rx Attenuators.
- [6] LNA On: Tx pre-amplifier gain of +31dB.
- [7] 75Ω impedance is optional using the SMA/BNC adaptor.
- [8] RFoF units for (-)40°C — 85°C are available.
- [9] Safety EN60950-1:2006(2nd); EMC: ETSI EN 300 386 v1.6.1 (2012-04) and FCC CFR-47-part 15 Sub part B..
- [10] Customer should order the MPO 4/8 optical cable (female) customer according to required length and conditions.
Example: GoFoton: P/N BPF3P1SM015FLR020 (4 fibers)/BPF3P1FM015FLR021 (8 fibers). XXX = 15m fiber length.
- [11] IP-54 Data, AC and DC opposite connectors are provided as accessories with the module (cables are not included).
- [12] DC and AC versions of the outdoor enclosures are available.
- [13] 2 cable clamps to secure the RFoF Tx/Rx units' power adapter cables are provided.
- [14] For USB control, download software here: rfoptic.com/software-download-rfof/ (Ask your local representative for password).

Programmable 2.5GHz RFoF – Simplified Block Diagram

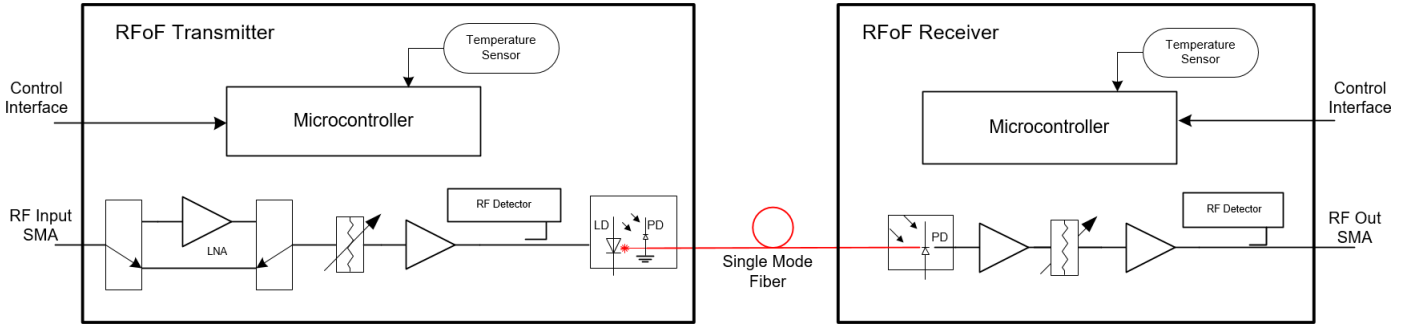

Programmable 2.5GHz RFoF - Test Results (Typical performance with Tx and Rx attenuators set to 0dB)

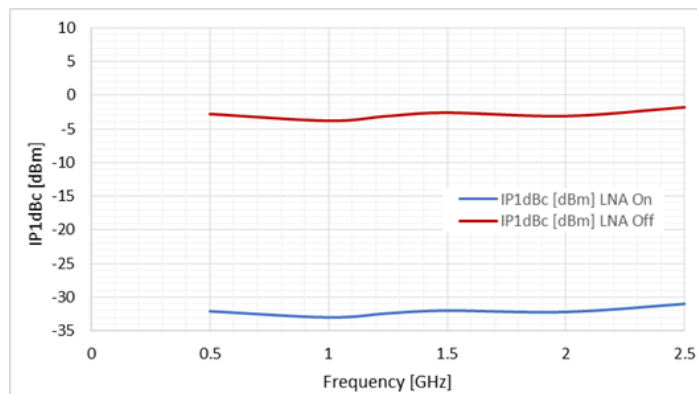
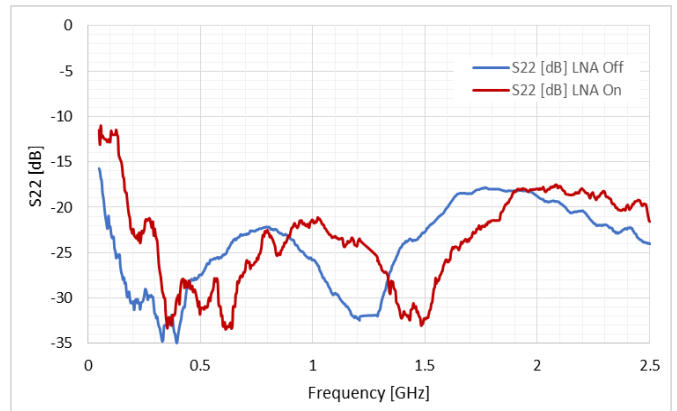
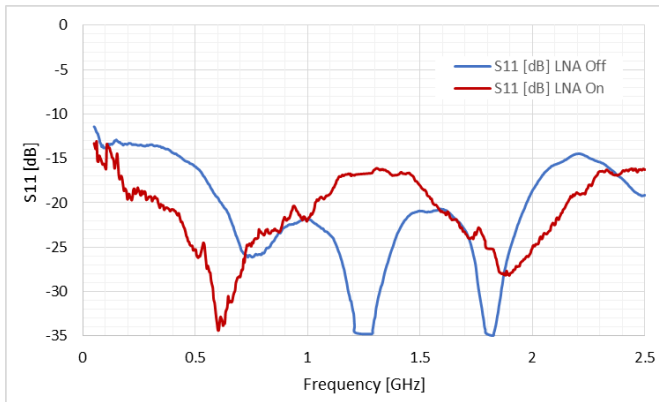
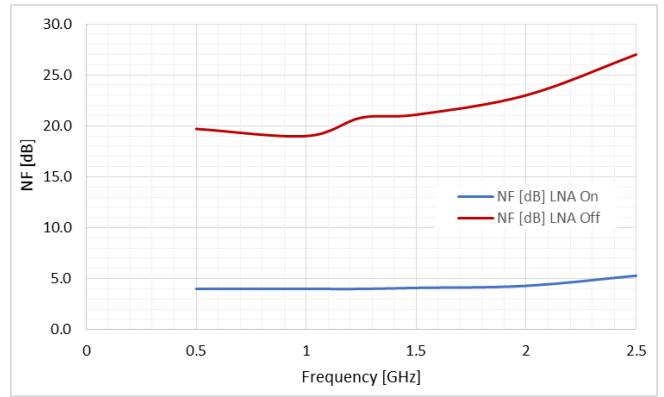
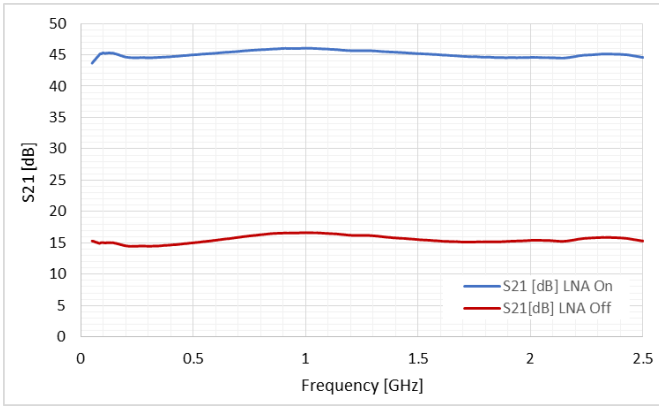

Mechanical Outline Drawing: Programmable 2.5GHz RFoF Rx & Tx units

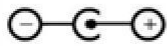
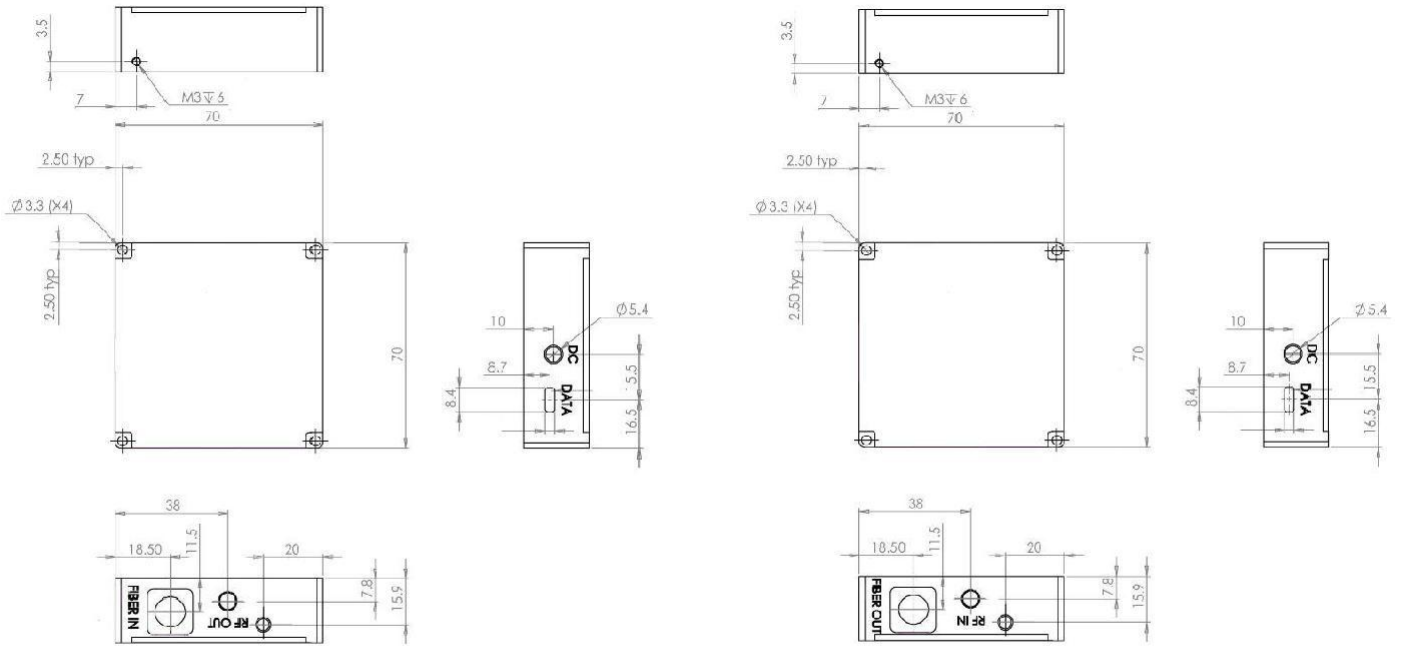

Connector: Positive center plug OD: 3.5mm, ID: 1.3mm, L: 9mm

Ordering Information

Part Number	Product Description	Tx	Rx
RFoF-2.5GHz-1310	2.5GHz Transceiver 1310, FC/APC, Programmable	RFoF2T3FR-PA-11	RFoF2R3FR-PA-11
RFoF-2.5GHz-1550	2.5GHz Transceiver 1550, FC/APC, Programmable	RFoF2T5FR-PA-11	RFoF2R5FR-PA-11
RFoF-AC-DC-Prog	2*220/110 AC/5VDC adapter for Programmable*	—	—
RFoF-AC-DC-Prog-1	1*220/110 AC/5VDC adapter for Programmable	—	—

* Since each RFoF module requires one AC/DC adapter, 2 adapters will be needed for a link.

Options:

- For outdoor or rack mount options, please contact RFOptic.
- SC/APC adaptor is an option
- 8mW Optical Power