

Multi-Channel Programmable 4.0GHz RF over Fiber Bi-Dir System



Generic photo used for illustration purpose only. See RFoF 4GHz Bi-directional sub-system modules drawings in page #3.

RFOptic's multi-channel programmable RFoF Bi-directional system provides RF performance that is superior to coaxial cable interface. The system is composed of 4 RFoF bi-directional terminals that are connected to each other by 4 single mode fibers (SMF). It is tailored to the 5G cellular band and covers the entire 0.5GHz to 4.0GHz bandwidth. This 4-channel system is offered with four RFoF Tx units and four RFoF Rx units in each enclosure. The system contains two different enclosures which should be deployed as follows: one at the base station side (B7) and another at the User Equipment side (B8). The B7 enclosure contains fully bi-directional RF ports with a wideband high isolation RF combiner which is used to feed the RFoF Tx uplink and combine the RF output of the Rx downlink of each terminal. The B8 enclosure contains the counterpart RFoF terminals but with independent RF ports for the uplink and downlink signals. Optical wavelength separation is used to transmit both uplink and downlink signals of each port over the same fiber. A diagram on page 2 of this brochure provides details of the RF and Optical configuration. This configuration is supported by RFOptic's sub-system remote management and control functionality through HTML/REST/SNMP interface allow the system to handle very different application requirements.

Key Features:

- Integrated and flexible multi-channel RFoF sub-systems.
- Full support for the 0.4GHz to 4.0GHz bandwidth.
- Excellent linearity, gain flatness, and gain control.
- Programmable RF and Optical performance.
- Built-in end-to-end diagnostics reduces installation and maintenance time.
- Integrated RF power sensors.
- Reduced gain variation over temperature option.
- Remote management and control via HTML/REST/SNMP interface

Both enclosures are Tx and Rx RFoF terminal units.

Each of these include LNAs and variable attenuators which can be used to customize the Noise Figure, Input P1dB, and IP3 over wide range of values. For special applications requiring temperature stability operation, a unique optional temperature compensation algorithm supports ± 0.5 dB over 1000C variation of the ambient temperature. The RFoF link has excellent gain flatness with 0.5dB gain adjustment and tracking between different links.

Configuration:

- Two 19" 1U indoor enclosures
- B7 cage with 4 optically multiplexed pairs of RFoF Tx 1310nm and 4 Rx units integrated with combiners.
- B8 cage with 4 optically multiplexed pairs of RFoF Tx 1550nm and 4 Rx units.

Applications:

- 5G test sites
- DAS
- Distributed Antenna

Each of the signals is transmitted over an RFoF programmable link. A simplified block diagram of such a link is shown below.

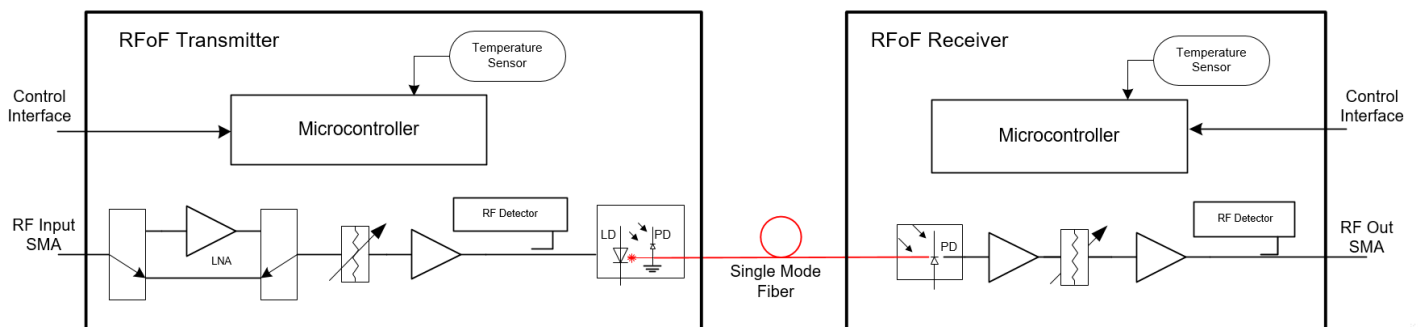

Multi-Channel Programmable 4.0GHz RF over Fiber Bi-Dir System Specifications

RF Performance ^[1]	Unit	Specification (typical)	
		LNA Off	LNA ON
Frequency Range	MHz	400 - 4000	400 - 4000
Nominal Link Gain (adjustable) ^[2]	dB	10	40
Tx/Rx Attenuators 0 to 31dB, 0.5 step	dB	0.5	0.5
Gain Flatness	dB	±2	±2
Input P1dBc ^[3]	dBm	0	-31
Noise Figure ^[3]	dB	25	7
Calculated SFDR ^[3]	dB/Hz ^{2/3}	105	97
Max Input Return Loss	dB	-12	-12
Max Output Return Loss	dB	-12	-12
Maximum Input No damage	dBm	+20	+20
Input / Output impedance	Ohm	50	50
Optical and Electrical			
Laser diode wavelength ^[4]	µm	1.310 & 1.550	
System Monitor & Control	-	HTML/REST/SNMP	
Optical Power ^[5]	mw	3	
Power	-	110/220 VAC	
Mechanical and Environmental Parameters			
19" 1U Enclosure dimensions	mm	445(W)* 476(L)* 44(H)	
Number of bi-directional links	-	4	
RF Input/Output Connectors	-	SMA	
Optical Connectors	-	LC/UJC	
Power Connectors	-	HP Socket	
Data Connector	-	RJ-45	
Operating temperature	°C	-20 to +70	
Storage temperature	°C	-40 to +85	

[1] The specifications are for 4.0GHz RFoF link between enclosures B7 and B8 connected with short patch fibers.

[2] The link Gain and IP1dB can be adjusted by the Tx Attenuator using the user software.

[3] Noise Figure and Input P1 dB are measured at 2GHz and can be adjusted by using the Tx Attenuator and 'LNA Off/On'.

[4] Minimum optical power 1.6mW (2dBm).

Bidirectional Multi-channel 4 RFoF sub-system block diagrams

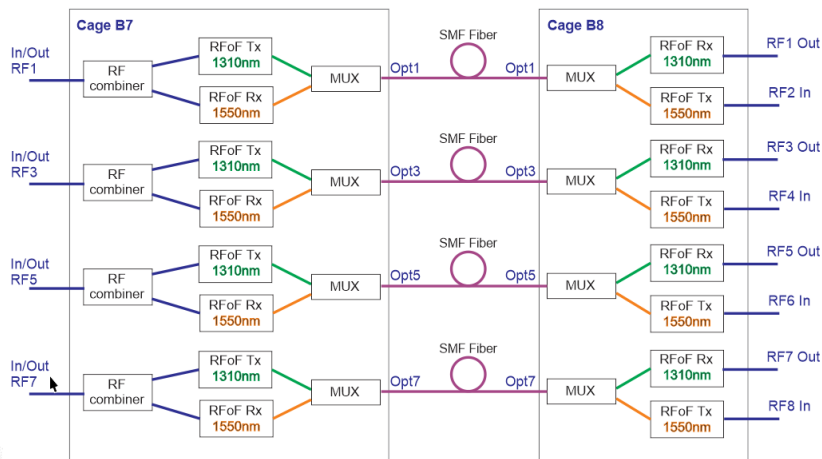

Multi-Channel Programmable 4.0GHz Bi-Directional RF over Fiber Subsystem, February 2026

Tel. Int.:+972-76-540 0180 • Tel. USA: +1 708 RFOPTIC, 21 Yegi'a Kapayim, Building C, 3rd Floor 4913020 Petah Tikva, Israel

www.rfoptic.com

19" 1U enclosure drawings

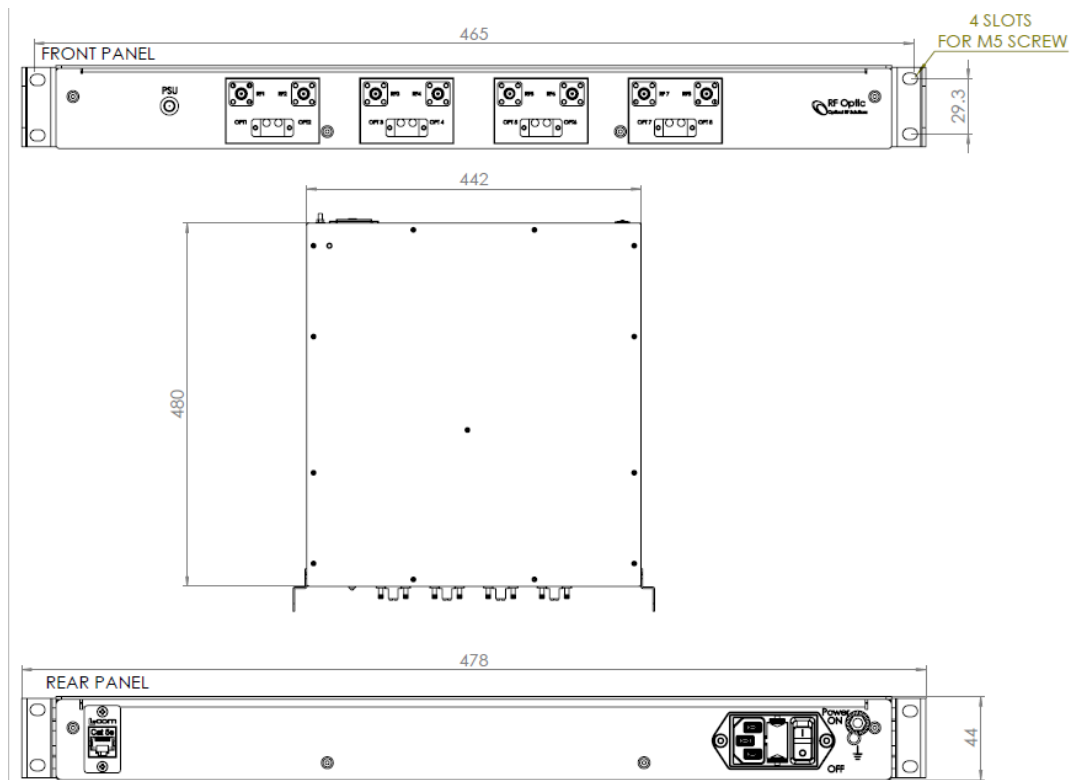

Ordering Information:

For specific configuration, define the following:

1. Enclosure type – 19" 1U Generic
2. Upper Frequency - 4.0GHz
3. Four of bi-directional terminals
4. Communication type - HTML
5. Power –220 VAC
6. Optical connectors - LC/UPC
7. RF connectors – SMA

Part Number	Description
RFoFc-I1SL4T4RIHNA04B7	19" 1U Enclosure with 4*RFoF 4GHz bidirectional 1310nm terminals, 4*SMA, 4*LC/UPC, 4*Combiners, 4*1310/1550nm multiplexers, HTML, 220VAC
RFoFc-I1SL4T4RIHNA04B8	19" 1U Enclosure with 4*RFoF 4GHz bidirectional 1310nm terminals, 4*SMA, 4*LC/UPC, 4*1310/1550nm multiplexers, HTML, 220VAC