

Programmable Phase Matched 6.0GHz RF over Fiber system



Key Features:

- Supports 0.5MHz up to 6.0GHz.
- Phased matched CWDM system of $\pm 7.5^\circ$
- Gain matched 6.0GHz full band of $\pm 2.5\text{dB}$
- Excellent linearity, gain flatness, and gain control in both Tx and Rx terminals.
- Noise Figure down to 6dB (link) and 10dB (system) with LNA On.
- Excellent Phase Noise.
- System reaches MDS $\sim 164\text{dB/Hz}$ for very low incoming signals and.
- Built-in end-to-end link diagnostics reduces installation and maintenance time, enabled by software.
- Gain variation S21 of $\pm 1\text{dB}$ for 100°C range, utilizing special algorithm.
- Remote management supporting USB with software or Ethernet webserver.
- Impedances of 50 Ohms and 75 Ohm.
- Outdoor solution including IFL capability to control the remote side and provide gigabit ethernet transport.

Applications:

- Phased Array Radar
- Electronic Warfare
- Interferometry

RFOptic presents its innovative controllable Phased Matched system RFoF product line.

RFOptic CWDM 6.0GHz RFoF 4 link system is phase matched to $\pm 7.5^\circ$ up to 6.0GHz. Each of the four links is comprised of a Tx unit with integrated LNA and an Rx unit, both with variable attenuators that enable adjustment of the Gain, Noise Figure, Input P1dB, and IP3 over wide range of values. The LNA can be activated through an RFoF software tool allowing RF input MDS of -108 dBm @ 1MHz bandwidth. It is especially suitable for low signal wideband applications, with a low Noise Figure under 10dB when integrated in the phase matched system with the common fiber. Each RFoF link has excellent gain flatness with 0.5dB gain adjustment step and good tracking among different RFoF links. For special applications requiring temperature stability, a unique algorithm supporting under $\pm 1\text{dB}$ over 100°C range is available.

A user-friendly RFoF software enables adjustment of the RF and Optical parameters, such as link gain, Noise Figure, P1dB, Optical power, LED indication and module information, either locally over USB connection or remotely with Ethernet enabled Management & Control.

Furthermore, each RFoF link has full built-in diagnostic capability including Tx, Rx self-test and complete link test (Optical and RF). These features save cost of test equipment and provide real time diagnostic of any deployed link.

Programmable Phase Matched 6.0GHz RF over Fiber System Specifications

Electrical	Unit	System Specification LNA Off	System Specification LNA On
Frequency Range	MHz	1 - 6000	1 - 6000
Adjustable Link Gain (nominal value) ^[1]	dB	2	32
Gain Flatness	dB	±2.5	±2.5
Input P1 dB ^[1,2]	dBm	0	-33
Noise Figure ^[1,2]	dB	32	10
Phased matched up to 8 links with optical cable up to 100m ^[3,5]	deg	≤ ±7.5	≤ ±7.5
Phased matched up to 8 links with optical cable up to 1.0Km ^[3,5]	deg	≤ ±10	≤ ±10
Gain matched up to 8 links ^[4]	dB	≤ ±2.5	≤ ±2.5
SFDR ^[1,2]	dB/Hz ^{2/3}	101	87
Maximum Input No damage	dBm	20	20
Spurious	dBc	-85	-75
Phase Noise at 6GHz at 10KHz Offset	dBc/Hz	-135	-
VSWR Input / Output	dBm	2:1	2:1
Input / Output impedance	Ohm	50	50
Optical and Electrical			
Laser diode wavelengths - 4 links	-	CWDM	
Optical Power in the fiber (per link)	mW	2.3 ±0.5	
Optical and RF Monitoring Capability	-	Yes	
System Monitor & Control - RF and Optical parameters	-	USB or HTML/REST/SNMP	
Mechanical and Environmental Parameters			
Operating temperature	°C	-25 to +65	
Storage temperature	°C	-40 to +85	
EMC and Safety ^[6]	-	CE & FCC	
Environmental & EMI/EMC Safety		CE, FCC, MIL-STD-461F, DO-160G & MIL-STD-810F	
MIL Qualified (Ground / Airborne /Shipborne) Chassis. Customization can be done per customer requirement			
Fiber (Supplied with the system)	1Km 8/12 Core Rodent Deterrent Outdoor Tactical Fiber Cable		

[1] LNA 'ON' or 'OFF' is selected by RFOptic manufacturing, or by using the RFoF user software.

[2] Noise Figure and Input P1dBc are measured at 3.0GHz, for both LNA Off and ON. Input IP3 and SFDR are calculated values.

[3] For full frequency band, up to 6.0GHz and over temperature range of -25°C to +65°C.

[4] Using the Tx and/or Rx Attenuators.

[5] Including 1000m fiber connection.

[6] Safety EN60950-1:2006(2nd); EMC: ETSI EN 300 386 v1.6.1 (2012-04) and FCC CFR-47part 15 Sub part B.

[7] For an additional information of this product, see brochure of *Programmable 6.0GHz RF Over Fiber*.

Programmable 6.0GHz RFoF – Simplified Block Diagram

Each RFoF link is comprised of a Tx RFoF module and an Rx RFoF module. The following simplified block diagram illustrates the main components of such modules.

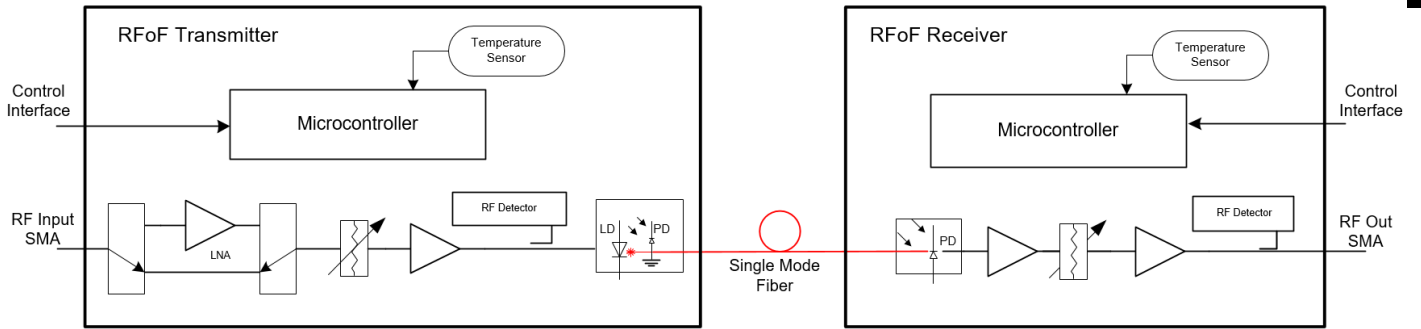

Programmable Phase Matched 6.0GHz RF over Fiber System Test Results

RFoF 6.0 GHz CWDM Relative Phase Error over Temperature for 4 links with LNA On

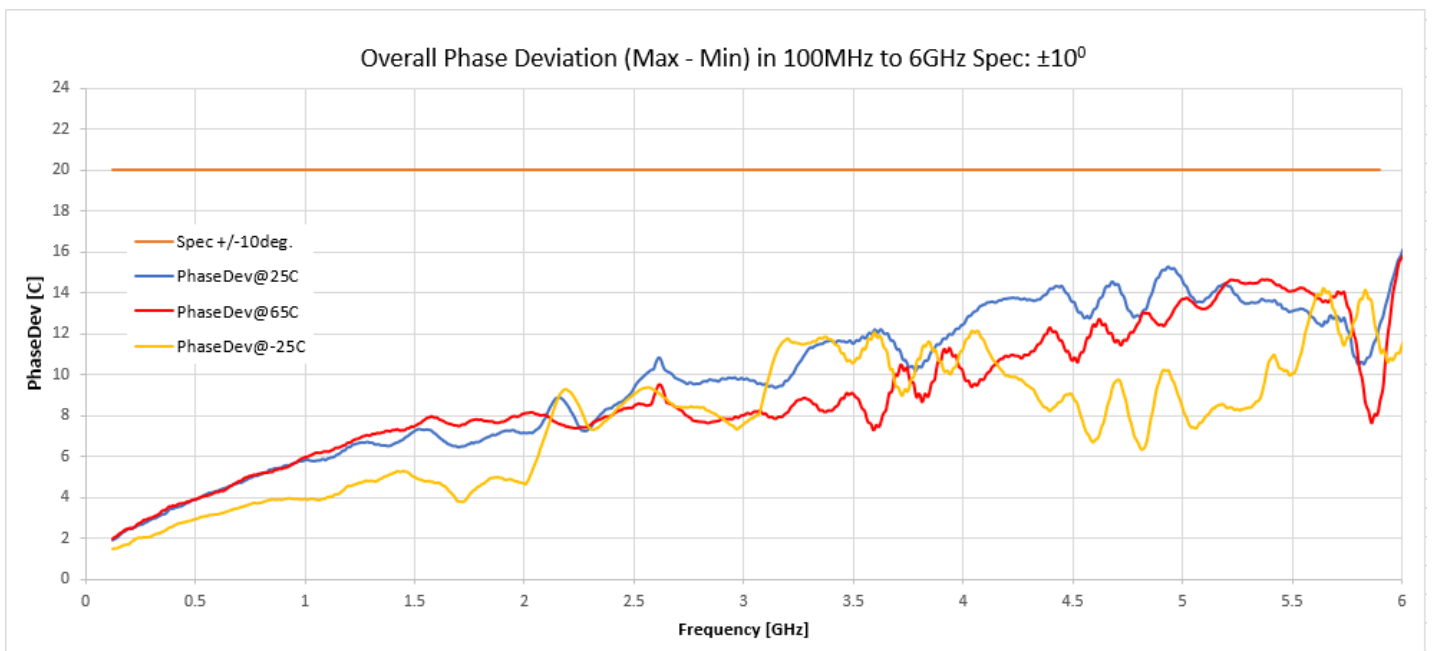

RFoF 6.0 GHz CWDM Gain Error over Temperature for 4 links with LNA On

Overall Gain Deviation (Max - Min) in 100MHz to 6GHz Spec: $\pm 2.5\text{dB}$

